

ClaronPolyseal®
Piston Bearing Rings

EBR

Metric

Nominal Dimensions & Machining Tolerances

Claron Part Number	H9	$\leq 100\text{mm} +0.0 -0.05$ $>100\text{mm} +0.0 -0.08$	± 0.20	± 0.40
	ØD_1	Ød_1	L_1	ØG
EBR 25	25	19	10.0	22
EBR 32	32	26	10.0	29
EBR 40	40	34	10.0	37
EBR 46	46	40	10.0	43
EBR 50	50	44	10.0	47
EBR 50/1	50	44	13.0	47
EBR 55	55	49	13.0	52
EBR 60	60	54	13.0	57
EBR 63	63	57	13.0	60
EBR 65	65	59	13.0	62
EBR 70	70	64	13.0	67
EBR 75	75	69	13.0	72
EBR 80	80	74	13.0	77
EBR 90	90	84	13.0	87
EBR 100	100	94	13.0	97
EBR 110	110	104	13.0	107
EBR 115	115	109	13.0	112
EBR 120	120	114	13.0	117
EBR 120/1	120	114	19.5	117
EBR 125	125	119	13.0	122
EBR 125/1	125	119	19.5	122
EBR 127	127	121	13.0	124
EBR 130	130	124	13.0	127
EBR 140	140	134	13.0	137
EBR 150	150	144	13.0	147
EBR 150/1	150	144	19.5	147
EBR 160	160	154	19.5	157
EBR 170	170	164	19.5	167
EBR 180	180	174	19.5	177
EBR 200	200	194	19.5	197
EBR 220	220	214	19.5	217
EBR 250	250	244	19.5	247

ClaronPolyseal®
Piston Bearing Rings

EBR

Imperial

Nominal Dimensions & Machining Tolerances

Claron Part Number	H9	$\leq 4.000'' + 0.000'' - 0.002''$ $> 4.000'' + 0.000'' - 0.003''$	± 0.004	± 0.010
	$\varnothing d_1$	$\varnothing D_1$	L_1	$\varnothing G$
EBR 1000	1.000	0.764	0.393	0.882
EBR 1250	1.250	1.014	0.393	1.132
EBR 1500	1.500	1.264	0.393	1.382
EBR 1750	1.750	1.514	0.393	1.632
EBR 2000	2.000	1.764	0.393	1.882
EBR 2001/1	2.000	1.764	0.512	1.882
EBR 2250	2.250	2.014	0.512	2.132
EBR 2500	2.500	2.264	0.512	2.382
EBR 2625	2.625	2.389	0.512	2.507
EBR 2750	2.750	2.514	0.512	2.632
EBR 3000	3.000	2.764	0.512	2.882
EBR 3250	3.250	3.014	0.512	3.132
EBR 3500	3.500	3.264	0.512	3.382
EBR 3750	3.750	3.514	0.512	3.632
EBR 4000	4.000	3.764	0.512	3.882
EBR 4500	4.500	4.264	0.512	4.382
EBR 4500/1	4.500	4.264	0.768	4.382
EBR 5000	5.000	4.764	0.512	4.882
EBR 5500	5.500	5.264	0.512	5.382
EBR 6000	6.000	5.764	0.512	5.882
EBR 6500	6.500	6.264	0.768	6.382
EBR 7000	7.000	6.764	0.768	6.882
EBR 7250	7.250	7.014	0.768	7.132
EBR 7500	7.500	7.264	0.768	7.382
EBR 8000	8.000	7.764	0.768	7.882
EBR 8250/1	8.250	8.014	0.512	8.132
EBR 8500	8.500	8.264	0.768	8.382
EBR 9000	9.000	8.764	0.768	8.882
EBR 9500	9.500	9.264	0.768	9.382

IBR

Nominal Dimensions & Machining Tolerances

Claron Part Number	f8	$\leq 115\text{mm} +0.05-0.00$ $> 115\text{mm} +0.08-0.00$	± 0.20	± 0.40
	$\text{Ø}d_2$	$\text{Ø}D_2$	L_1	$\text{Ø}G$
IBR 020	20	26	10.0	23
IBR 022	22	28	10.0	25
IBR 025	25	31	10.0	28
IBR 028	28	34	10.0	31
IBR 032	32	38	10.0	35
IBR 036	36	42	10.0	39
IBR 040	40	46	10.0	43
IBR 045	45	51	13.0	48
IBR 045	45	51	10.0	48
IBR 050	50	56	13.0	53
IBR 056	56	62	13.0	59
IBR 060	60	66	13.0	63
IBR 063	63	69	13.0	66
IBR 070	70	76	13.0	73
IBR 075	75	81	13.0	78
IBR 080	80	86	13.0	83
IBR 090	90	96	13.0	93
IBR 095	95	101	13.0	98
IBR 100	100	106	13.0	103
IBR 100/1	100	106	20.5	103
IBR 110	110	116	13.0	113
IBR 120	120	126	13.0	123
IBR 125	125	131	13.0	128
IBR 125/1	125	131	25.5	128
IBR 130	130	136	13.0	133
IBR 140	140	146	13.0	143
IBR 145	145	151	13.0	148

ClaronPolyseal®
Rod Bearing Rings
IBR

Imperial

Nominal Dimensions & Machining Tolerances

Claron Part Number	f8	$\leq 4.500'' + 0.002'' - 0.000''$ $> 4.500'' + 0.002'' - 0.000''$	± 0.004	± 0.010
	$\varnothing d_2$	$\varnothing D_2$	L_1	$\varnothing G$
IBR 1000	1.000	1.236	0.393	1.118
IBR 1125	1.125	1.361	0.393	1.243
IBR 1250	1.250	1.486	0.393	1.368
IBR 1375	1.375	1.611	0.393	1.493
IBR 1500	1.500	1.736	0.393	1.618
IBR 1750	1.750	1.986	0.393	1.868
IBR 1750/1	1.750	1.986	0.512	1.868
IBR 2000	2.000	2.236	0.512	2.118
IBR 2250	2.250	2.486	0.512	2.368
IBR 2375	2.375	2.611	0.512	2.493
IBR 2500	2.500	2.736	0.512	2.618
IBR 2625	2.625	2.861	0.512	2.743
IBR 2750	2.750	2.986	0.512	2.868
IBR 3000	3.000	3.236	0.512	3.118
IBR 3250	3.250	3.486	0.512	3.368
IBR 3375	3.375	3.611	0.512	3.493
IBR 3500	3.500	3.736	0.512	3.618
IBR 3625	3.625	3.861	0.512	3.743
IBR 3750	3.750	3.986	0.512	3.868
IBR 4000	4.000	4.236	0.512	4.118
IBR 4250	4.250	4.486	0.512	4.368
IBR 4375	4.375	4.611	0.512	4.493
IBR 4500	4.500	4.736	0.512	4.618
IBR 4750	4.750	4.986	0.512	4.868
IBR 5000	5.000	5.236	0.512	5.118
IBR 5500	5.500	5.736	0.512	5.618

ClaronPolyseal® Bearing Tape BT/CT

Metric

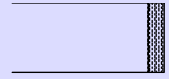

Design

This range of products is designed for use in hydraulic and pneumatic piston and gland applications to minimise the problems of metal to metal contact by inexpensive means. Produced from wear resistant filled grades of PTFE with its known properties of low friction, these products eliminate 'stiction' between moving parts, reduce 'nibbling' of the seal at high pressures due to radial movement and are easily assembled.

Materials

For hydraulic applications we recommend CLARON P.T.F.E. bearing tape with a **Bronze filling**. Style **BT...**
For pneumatic applications we recommend CLARON P.T.F.E. bearing tape with a **Carbon filling**. Style **CT...**
Other materials are available and the table in Appendix 2 should be carefully considered.
Consult CLARON for further advice on alternative materials.

Operating Range

Temp. -60°C to 200°C

Velocity 15m/sec

These range parameters are maximum conditional values.

Refer to "Bearing Selection" page E0-1 and "Bearing Materials" in Appendix 1.

How To Order

Example:

Hydraulic application, section 2mm, width 9.7mm, Bore 100mm,
Reciprocating application.(R cut): **BT 20097/304/R**

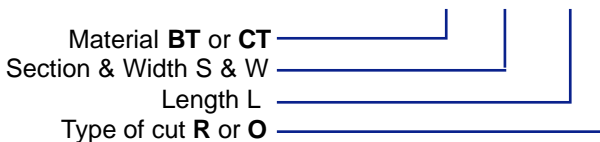

TAPE LENGTH 'L'

(For Temperatures upto 120°C)

Piston Application (mm)

$$L = \pi(0.99\phi D_1 - S) - 1$$

Rod Application (mm)

$$L = \pi(0.99\phi d_2 + S) - 1$$

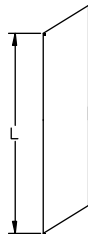

For rolls of tape, quote length required and material / size code. e.g. 15m **BT 25097**

TYPE OF CUT

Reciprocating Application Suffix **R**

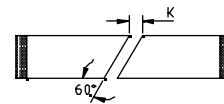

Rotary or Oscillating Application Suffix **O**

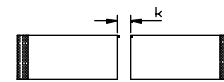

TAPE WIDTH 'W'

In new designs, the choice of tape width 'W' is determined by formula based upon load, diameter and material capability under the given operating conditions.

Note:

Refer also to "Bearing Selection" page E0-1.

Housing

For surface finish and recommended lead in chamfers refer to the illustration below. For housing dimensions and machining tolerances refer to the catalogue page of selected seal. Refer to Appendix 4 for value of tolerance symbols.

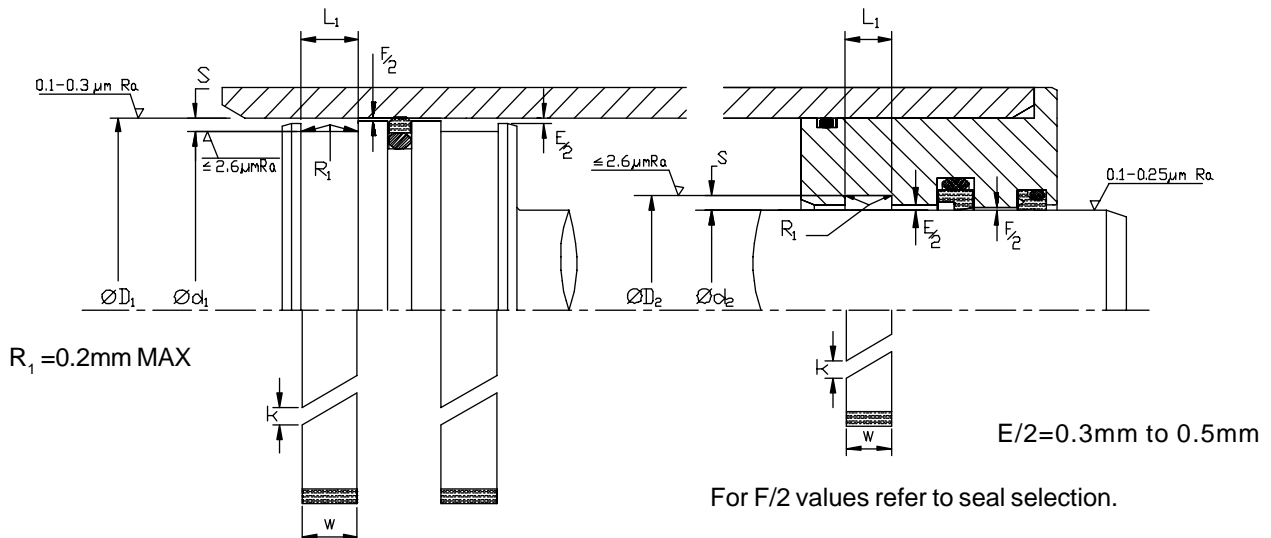

Bearing Material

Claron P.T.F.E. Bearing Tape is specifically designed for use with P.T.F.E. Composite Seals. The nature of P.T.F.E. allows for a manufactured size giving a tighter fit than 'harder' materials such as Phosphor-Bronze, Meehanite or Polyester Fabric. This reduction in radial clearance gives a marginal improvement to the pressure capability of the seal but, more importantly, protects the seal from contaminant particles within the system. A combination of the design of the bearing and the characteristics of P.T.F.E. allow the particles to become embedded in the P.T.F.E. on the non-working face, thus also protecting the steel counterface from scoring. During use, bearing materials wear, causing debris and contamination of the fluid. Extensive tests have shown that particulate contamination >15µm within the fluid, increases with the use of Phosphor-Bronze or Meehanite, and tends to decrease with the use of P.T.F.E. The harder debris created

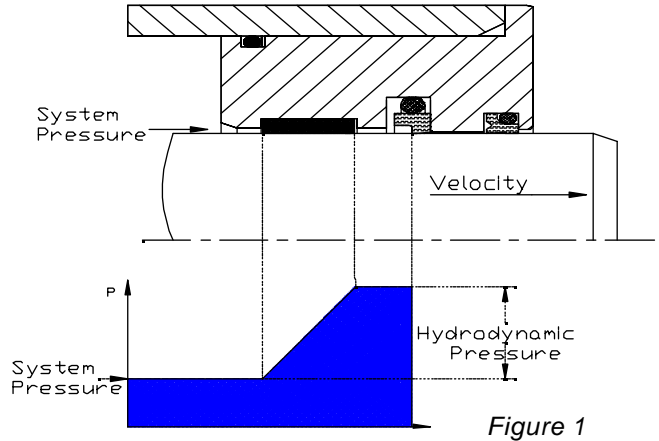

Figure 1

by these bearings also has a greater effect upon seal performance. Particulate contamination in the fluid surrounding the seal can be over 100 times that in the main system due to the bearing preventing flushing of the seal space. Increased contamination in this area will increase the probability of a large enough particle gaining access to the seal interface, causing damage and leakage. **Claron P.T.F.E. Bearing Tape** is designed to allow pressure relief to the seal by use of the expansion gap (**k**). This avoids the possibility of a pressure lock between the seal and the bearing, as well as eliminating the possibility of Hydrodynamic pressure build-up (shown in Figure 1) causing premature destruction of the seal.

This relief also avoids the presence of excess pressure during the return stroke which can prevent the transfer of the fluid film back to the pressure side of the seal, so creating the effect of a leaking seal. Pressure relief should be incorporated within the design of continuous bearings, particularly for fast cycling applications. The advantages of **Claron P.T.F.E. Bearing Tape** are not restricted to **Composite Seals** but apply to Nitrile and Polyurethane Seals.

Consideration of Radial Load

The maximum radial load applied to the bearings will determine both the width 'W' of the tape and number of bearings to be used. This can be calculated based on the radial force and the maximum permissible load capacity of the material at a given temperature. In the case of either lubricated dynamic, or unlubricated static applications **BRONZE filled P.T.F.E.** tape should be used and the value of 'P' should be taken from graph 1 shown below.

In the case of unlubricated Dynamic applications, friction has a much greater effect on the material which reduces the permissible load capacity of the material as the velocity increases. Therefore to allow for the effect of velocity, the load capacity P taken from graph 1 for **CARBON filled P.T.F.E.** should be reduced by multiplying it by a factor f taken from graph 2.

Lubricated Dynamic Conditions

$$W = \frac{F \max}{P \times n \times d}$$

Where:-

- W=Minimum Tape Width (mm)
- n=Number of Bearings
- F=Maximum Radial Force (Kp)
- d=Inside diameter of tape(mm)
- P=Permissible load capacity N/mm²)
- f=Reduction Factor

Unlubricated Dynamic Conditions

$$W = \frac{F \max}{P \times f \times n \times d}$$

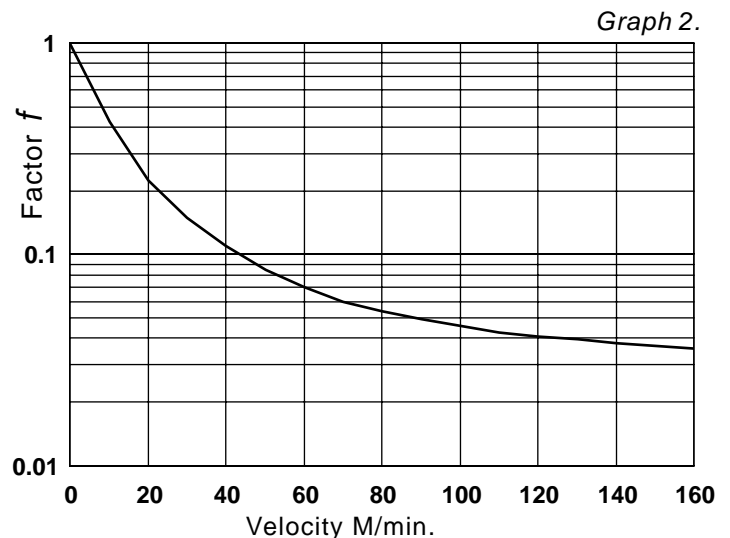
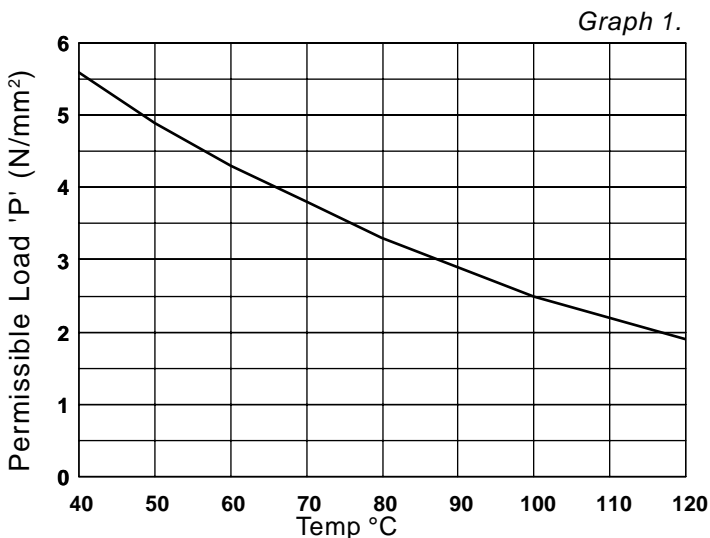

ClaronPolyseal®
Bearing Tape
BT/CT

Metric

Nominal Dimensions & Machining Tolerances

Claron Part Number Prefix BT CT	S	W	Min Ø Ød1	Min Ø ØD2	≤100mm +0.00 -0.05	≤115mm +0.05 -0.00	+0.20
					>100mm +0.00 -0.08	>115mm +0.08 -0.00	-0.00
					Ød ₁	ØD ₂	L ₁
15032	1.5	3.0	10	10	D ₁ -3.0	d ₂ +3.0	3.2
15063	1.5	6.1	15	10	D ₁ -3.0	d ₂ +3.0	6.3
15097	1.5	9.5	30	25	D ₁ -3.0	d ₂ +3.0	9.7
15150	1.5	14.8	45	35	D ₁ -3.0	d ₂ +3.0	15.0
15200	1.5	19.8	50	40	D ₁ -3.0	d ₂ +3.0	20.0
15250	1.5	24.8	100	80	D ₁ -3.0	d ₂ +3.0	25.0
15300	1.5	29.8	110	110	D ₁ -3.0	d ₂ +3.0	30.0
15400	1.5	39.8	110	110	D ₁ -3.0	d ₂ +3.0	40.0
20063	2.0	6.1	20	15	D ₁ -4.0	d ₂ +4.0	6.3
20081	2.0	7.9	30	25	D ₁ -4.0	d ₂ +4.0	8.1
20097	2.0	9.5	35	30	D ₁ -4.0	d ₂ +4.0	9.7
20100	2.0	9.8	35	30	D ₁ -4.0	d ₂ +4.0	10.0
20150	2.0	14.8	50	40	D ₁ -4.0	d ₂ +4.0	15.0
20200	2.0	19.8	75	60	D ₁ -4.0	d ₂ +4.0	20.0
20250	2.0	24.8	120	100	D ₁ -4.0	d ₂ +4.0	25.0
20300	2.0	29.8	130	130	D ₁ -4.0	d ₂ +4.0	30.0
20350	2.0	34.8	150	150	D ₁ -4.0	d ₂ +4.0	35.0
25056	2.5	5.4	25	20	D ₁ -5.0	d ₂ +5.0	5.6
25063	2.5	6.1	25	20	D ₁ -5.0	d ₂ +5.0	6.3
25081	2.5	7.9	35	30	D ₁ -5.0	d ₂ +5.0	8.1
25097	2.5	9.5	40	35	D ₁ -5.0	d ₂ +5.0	9.7
25100	2.5	9.8	40	35	D ₁ -5.0	d ₂ +5.0	10.0
25150	2.5	14.8	60	50	D ₁ -5.0	d ₂ +5.0	15.0
25200	2.5	19.8	90	75	D ₁ -5.0	d ₂ +5.0	20.0
25250	2.5	24.8	140	120	D ₁ -5.0	d ₂ +5.0	25.0
25300	2.5	29.8	150	150	D ₁ -5.0	d ₂ +5.0	30.0
30063	3.0	6.1	30	25	D ₁ -6.0	d ₂ +6.0	6.3
30081	3.0	7.9	45	40	D ₁ -6.0	d ₂ +6.0	8.1
30097	3.0	9.5	45	40	D ₁ -6.0	d ₂ +6.0	9.7
30100	3.0	9.8	45	40	D ₁ -6.0	d ₂ +6.0	10.0
30127	3.0	12.5	70	60	D ₁ -6.0	d ₂ +6.0	12.7
30150	3.0	14.8	70	60	D ₁ -6.0	d ₂ +6.0	15.0
30200	3.0	19.8	120	100	D ₁ -6.0	d ₂ +6.0	20.0
30250	3.0	24.8	160	140	D ₁ -6.0	d ₂ +6.0	25.0
30300	3.0	29.8	170	170	D ₁ -6.0	d ₂ +6.0	30.0
32056	3.2	5.4	35	30	D ₁ -6.4	d ₂ +6.4	5.6
32127	3.2	12.5	70	60	D ₁ -6.4	d ₂ +6.4	12.7
32190	3.2	18.8	120	100	D ₁ -6.4	d ₂ +6.4	19.0
32254	3.2	25.2	160	140	D ₁ -6.4	d ₂ +6.4	25.4
40063	4.0	6.1	45	35	D ₁ -8.0	d ₂ +8.0	6.3
40086	4.0	7.9	50	40	D ₁ -8.0	d ₂ +8.0	8.1
40097	4.0	9.5	60	50	D ₁ -8.0	d ₂ +8.0	9.7
40150	4.0	14.8	80	70	D ₁ -8.0	d ₂ +8.0	15.0
40200	4.0	19.8	130	110	D ₁ -8.0	d ₂ +8.0	20.0
40250	4.0	24.8	180	160	D ₁ -8.0	d ₂ +8.0	25.0

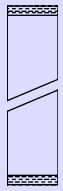
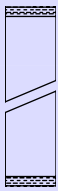

Design

Claron BGF bearing rings are designed for use on pistons or rods to align rod and piston and to prevent metal to metal contact. This bearing is precision moulded from a reinforced and heat stabilised grade of Nylon. The reinforcing fibres allows a higher than normal load capability and life span for this type of material. All Claron bearing rings are split to facilitate assembly, and to allow the passing of fluid. See the 'selection of bearing rings' at the beginning of this section for further application details.

Operating Conditions

Max. Operating Temp	110°C
Max. Linear Velocity	1.5 m/sec

See graph at the beginning of this section for load capacity values

How To Order

Order using the part number shown followed by a suffix denoting the type of cut required:-

Type	Suffix
Straight cut	/O
Angle cut	/R60 (where the number represents the angle required)

Continuous operating temperature for various fluids

PA Nylon		
DIN	Hydraulic Fluid Description	°C
H	Mineral oil without additives	120
H-L	Mineral Fluid with anti corrosion and anti ageing additives	120
H-LP	Mineral oil as HL plus additives reducing wear, raising load	120
H-LPD	Mineral oil as H-LP but with detergents and dispersants	120
H-V	Mineral oil as H-LP plus improved viscosity temp.	120
HFA E	Emulsions of mineral oil in water. Water content 80-95%	55
HFA S	Synthetic oil in water. Water content 80-95%	55
HFB	Emulsions of water in mineral oil. Water content 40%	60
HFC	Aqueous polymer solutions. Water content 35%	60
HFD R	Phosphoric acid ester based	80
HFD S	Chlorinated hydrocarbon based	80
HFD T	Mixtures of HFD R and HFD S	80
HEPG	Polyglycol based	100
HETG	Vegetable Oil based	60
HEES	Fully synthetic ester based	100

Housing

For surface finish and recommended lead in chamfers refer to the illustration below. For housing dimensions and machining tolerances refer to the catalogue page of selected seal. Refer to Appendix 4 for value of tolerance symbols.

Fitting

For the bearing to function correctly, it is important that care be taken in fitting the bearing within its housing. For a detailed checklist, refer to Appendix 3.

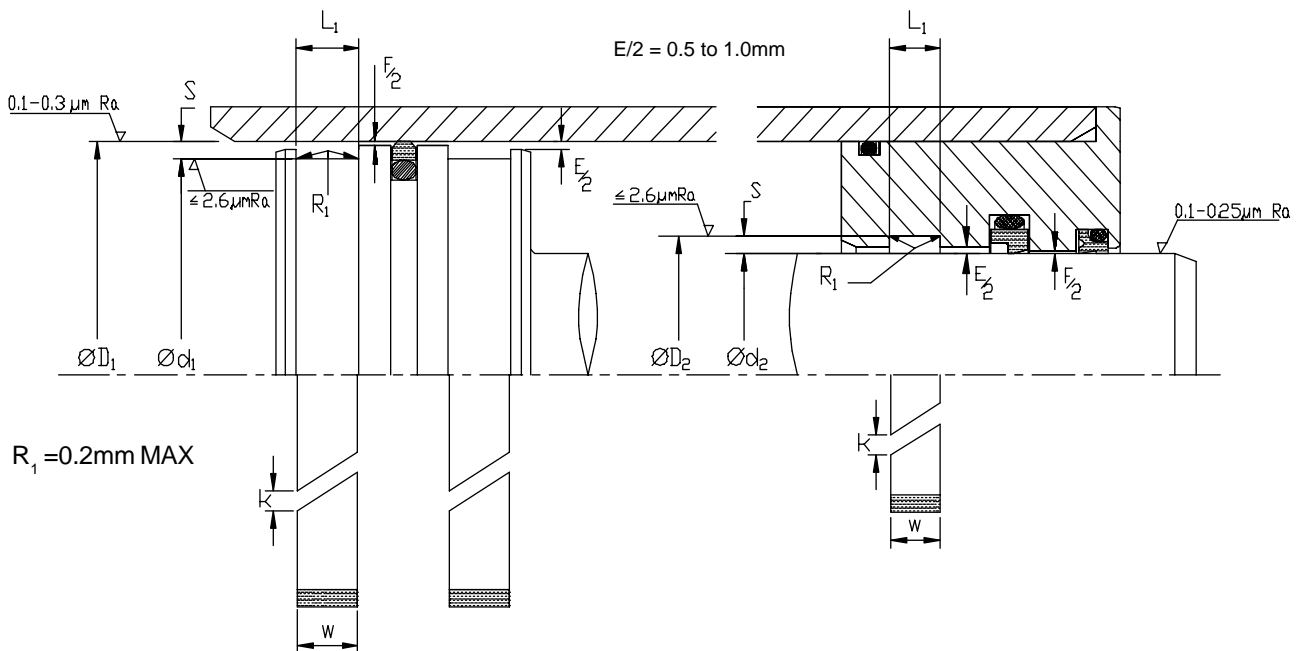

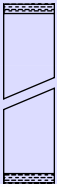

ClaronPolyseal®
Piston & Rod Bearing Rings

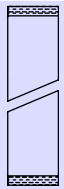

BGF

Metric

Nominal Dimensions & Machining Tolerances

Claron Part Number	H9	$\leq 100\text{mm} +0.00 -0.05$ $> 100\text{mm} +0.00 -0.08$	$\leq 100\text{mm} +0.00 -0.05$ $> 100\text{mm} +0.00 -0.08$	f8	$+0.20$ -0.00	E
	$\varnothing D_1$	$\varnothing D_2$	$\varnothing d_1$	$\varnothing d_2$	L_1	
BGF 032028960/	32		28		9.6	1.0 to 2.0
BGF 050044090/	50		44		9.0	
BGF 065061080/	65		61		8.0	
BGF 065061100/	65		61		10.0	
BGF 068064100/	68		64		10.0	
BGF 070065205/	70		65		20.5	
BGF 075071100/	75		71		10.0	
BGF 080076100/	80		76		10.0	
BGF 085081100/	85		81		10.0	
BGF 100095150/	100		95		15.0	
BGF 105101150/	105		101		15.0	
BGF 115111150/	115		111		15.0	
BGF 120116150/	120		116		15.0	

PBR

Design

Claron PBR bearing rings are designed for use on pistons or rods to align rod and piston and to prevent metal to metal contact. This bearing is precision machined from a reinforced grade of Phenolic resin. The thermoset properties of this material allows a high load capability even at higher temperatures. All Claron bearing rings are split to facilitate assembly, and to allow the passage of fluid.

See the 'selection of bearing rings' at the beginning of this section for further application details.

Operating Conditions

Max. Operating Temp. (Intermittent)	150°C
Max. Operating Temp. (Continuous)	120°C
Max. Linear Velocity	3m/sec

See graph at the beginning of this section for load capacity values

How To Order

Order using the part number shown followed by a suffix denoting the type of cut required:-

Type	Suffix
Straight cut	/O
Angle cut	/R60 (where the number represents the angle required)

Housing

For surface finish and recommended lead in chamfers refer to the illustration below. For housing dimensions and machining tolerances refer to the catalogue page of selected seal.

Refer to Appendix 4 for value of tolerance symbols.

Fitting

For the bearing to function correctly, it is important that care be taken in fitting the bearing within its housing.

For a detailed checklist, refer to Appendix 3.

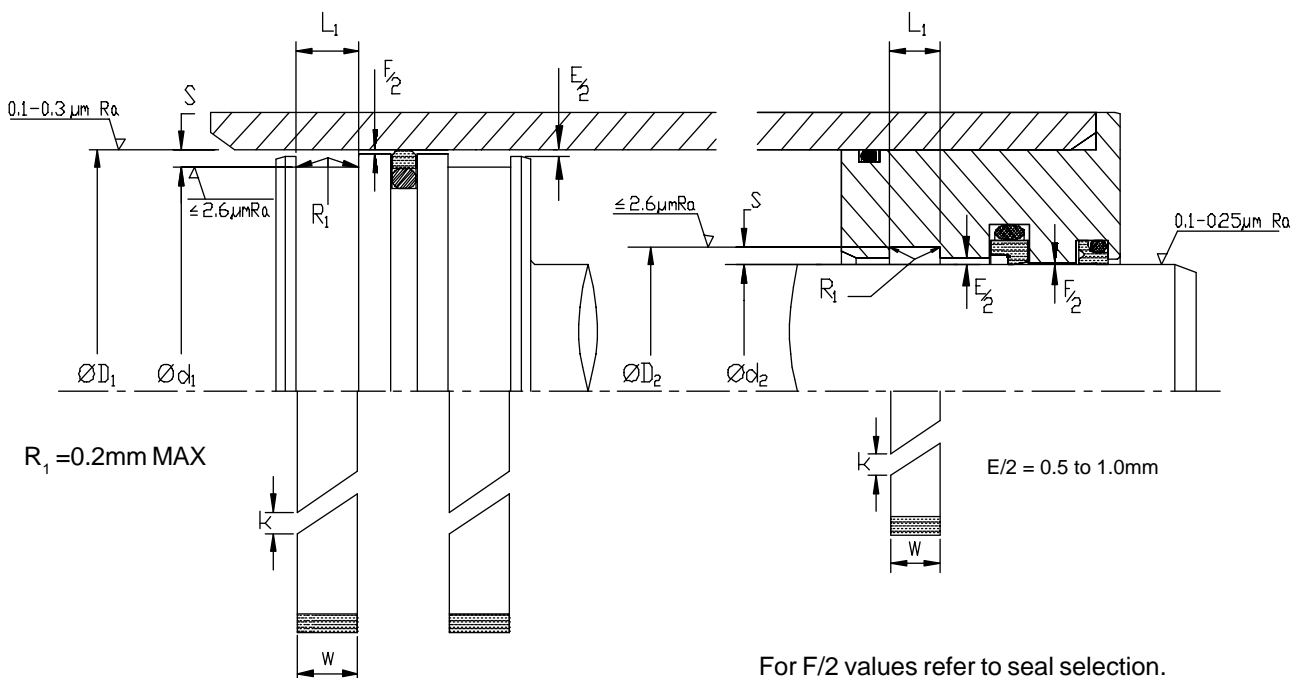

ClaronPolyseal®
Piston & Rod Bearing Rings

PBR

Metric

Nominal Dimensions & Machining Tolerances

Claron Part Number	H9		f8		+0.20 -0.00 L ₁	Nom. Sec. S	E
	≤100mm+0.00-0.05 >100mm+0.00-0.08	≤100mm+0.00-0.05 >100mm+0.00-0.08	ØD ₁	ØD ₂			
PBR 016011056	16		11.0		5.6	2.5	
PBR 020017040	20		16.9		4.0	1.55	
PBR 020016080	20		16.0		8.0	2.0	
PBR 020015056	20		15.0		5.6	2.5	
PBR 025022040	25		21.9		4.0	1.55	
PBR 025021080	25		21.0		8.0	2.0	
PBR 025020056	25		20.0		5.6	2.5	
PBR 025020097	25		20.0		9.7	2.5	
PBR 030027040	30		26.9		4.0	1.55	
PBR 030026080	30		26.0		8.0	2.0	
PBR 030025056	30		25.0		5.6	2.5	
PBR 030025097	30		25.0		9.7	2.5	
PBR 032029040	32		28.9		4.0	1.55	
PBR 032027056	32		27.0		5.6	2.5	
PBR 032027097	32		27.0		9.7	2.5	
PBR 035032040	35		31.9		4.0	1.55	
PBR 035031010	35		31.0		10.0	2.0	
PBR 035030056	35		30.0		5.6	2.5	
PBR 035030097	35		30.0		9.7	2.5	
PBR 040037040	40		36.9		4.0	1.55	
PBR 040036010	40		36.0		10.0	2.0	
PBR 040035056	40		35.0		5.6	2.5	
PBR 040035097	40		35.0		9.7	2.5	
PBR 045042040	45		41.9		4.0	1.55	
PBR 045040080	45		40.0		8.0	2.5	
PBR 045040056	45		40.0		9.7	2.5	
PBR 045040097	45		40.0		9.7	2.5	
PBR 045040150	45		40.0		15.0	2.5	
PBR 050047040	50		46.9		4.0	1.55	
PBR 050045056	50		45.0		5.6	2.5	
PBR 050045063	50		45.0		6.3	2.5	
PBR 050045080	50		45.0		8.0	2.5	
PBR 050045097	50		45.0		9.7	2.5	
PBR 050045150	50		45.0		15.0	2.5	
PBR 050044125	50		44.0		12.5	3.0	
PBR 055050056	55		50.0		5.6	2.5	
PBR 055050080	55		50.0		8.0	2.5	
PBR 055050097	55		50.0		9.7	2.5	
PBR 055050150	55		50.0		15.0	2.5	
PBR 060055056	60		55.0		5.6	2.5	
PBR 060055080	60		55.0		8.0	2.5	
PBR 060055097	60		55.0		9.7	2.5	
PBR 060055150	60		55.0		15.0	2.5	
PBR 060054125	60		54.0		12.5	3.0	
PBR 063058056	63		58.0		5.6	2.5	

1.0 to 2.0

ClaronPolyseal®
Piston & Rod Bearing Rings

PBR

Metric

Nominal Dimensions & Machining Tolerances

Claron Part Number	H9 $\begin{matrix} \leq 100\text{mm} +0.00 -0.05 \\ >100\text{mm} +0.00 -0.08 \end{matrix}$		f8 $\begin{matrix} \leq 100\text{mm} +0.00 -0.05 \\ >100\text{mm} +0.00 -0.08 \end{matrix}$		+0.20 -0.00 L ₁	Nom. Sec. S	E
	ØD ₁	ØD ₂	Ød ₁	Ød ₂			
PBR 063058063	63		58.0		6.3	2.5	
PBR 063058097	63		58.0		9.7	2.5	
PBR 065060056	65		60.0		5.6	2.5	
PBR 065060097	65		60.0		9.7	2.5	
PBR 065060010	65		60.0		10.0	2.5	
PBR 065060150	65		60.0		15.0	2.5	
PBR 065060200	65		60.0		20.0	2.5	
PBR 068063063	68		63.0		6.3	2.5	
PBR 070065056	70		65.0		5.6	2.5	
PBR 070065097	70		65.0		9.7	2.5	
PBR 070065010	70		65.0		10.0	2.5	
PBR 070065150	70		65.0		15.0	2.5	
PBR 070065200	70		65.0		20.0	2.5	
PBR 070064125	70		64.0		12.5	3.0	
PBR 075070056	75		70.0		5.6	2.5	
PBR 075070063	75		70.0		6.3	2.5	
PBR 075070097	75		70.0		9.7	2.5	
PBR 075070100	75		70.0		10.0	2.5	
PBR 075070150	75		70.0		15.0	2.5	
PBR 080075056	80		75.0		5.6	2.5	
PBR 080075097	80		75.0		9.7	2.5	
PBR 080075100	80		75.0		10.0	2.5	
PBR 080075100	80		75.0		10.0	2.5	
PBR 080075150	80		75.0		15.0	2.5	
PBR 080075200	80		75.0		20.0	2.5	
PBR 080074125	80		74.0		12.5	3.0	
PBR 085080056	85		80.0		5.6	2.5	
PBR 085080063	85		80.0		6.3	2.5	
PBR 085080097	85		80.0		9.7	2.5	
PBR 085080150	85		80.0		15.0	2.5	
PBR 085079150	85		79.0		15.0	3.0	
PBR 085079250	85		79.0		25.0	3.0	
PBR 090085056	90		85.0		5.6	2.5	
PBR 090085097	90		85.0		9.7	2.5	
PBR 090085150	90		85.0		15.0	2.5	
PBR 090084125	90		84.0		12.5	3.0	
PBR 090084150	90		84.0		15.0	3.0	
PBR 090084250	90		84.0		25.0	3.0	
PBR 095090056	95		90.0		5.6	2.5	
PBR 095090097	95		90.0		9.7	2.5	
PBR 095090150	95		90.0		15.0	2.5	
PBR 095089150	95		89.0		15.0	3.0	
PBR 095089250	95		89.0		25.0	3.0	
PBR 100095056	100		95.0		5.6	2.5	
PBR 100095097	100		95.0		9.7	2.5	

1.0 to 2.0

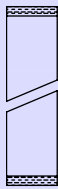

ClaronPolyseal®

Piston & Rod Bearing Rings

PBR

Metric



Nominal Dimensions & Machining Tolerances

Claron Part Number	H9		f8		+0.20 -0.00 L ₁	Nom. sec. S	E
	≤100mm+0.00-0.05 >100mm+0.00-0.08	≤100mm+0.00-0.05 >100mm+0.00-0.08	ØD ₁	Ød ₂			
PBR 100095150	100	95.0	15.0	2.5			
PBR 100094125	100	94.0	12.5	3.0			
PBR 100094150	100	94.0	15.0	3.0			
PBR 100094250	100	94.0	25.0	3.0			
PBR 105100056	105	100.0	5.6	2.5			
PBR 105100097	105	100.0	9.7	2.5			
PBR 105100150	105	100.0	15.0	2.5			
PBR 105099250	105	99.0	25.0	3.0			
PBR 110105056	110	105.0	5.6	2.5			
PBR 110105097	110	105.0	9.7	2.5			
PBR 110105150	110	105.0	15.0	2.5			
PBR 110104125	110	104.0	12.5	3.0			
PBR 110104150	110	104.0	15.0	3.0			
PBR 110104250	110	104.0	25.0	3.0			
PBR 115110056	115	110.0	5.6	2.5			
PBR 115110097	115	110.0	9.7	2.5			
PBR 115110150	115	110.0	15.0	2.5			
PBR 115109300	115	109.0	30.0	3.0		1.0 to 2.0	
PBR 115109300	115	109.0	30.0	3.0			
PBR 12015056	120	115.0	5.6	2.5			
PBR 120115097	120	115.0	9.7	2.5			
PBR 12015150	120	115.0	15.0	2.5			
PBR 120114125	120	114.0	12.5	3.0			
PBR 120114150	120	114.0	15.0	3.0			
PBR 120114300	120	114.0	30.0	3.0			
PBR 125120056	125	120.0	5.6	2.5			
PBR 125120097	125	120.0	9.7	2.5			
PBR 125120150	125	120.0	15.0	2.5			
PBR 125119150	125	119.0	15.0	3.0			
PBR 125119300	125	119.0	30.0	3.0			
PBR 130125097	130	125.0	9.7	2.5			
PBR 130125150	130	125.0	15.0	2.5			
PBR 130124125	130	124.0	12.5	3.0			
PBR 130123150	130	123.0	15.0	3.5			
PBR 130123300	130	123.0	30.0	3.5			
PBR 135130097	135	130.0	9.7	2.5			
PBR 135130150	135	130.0	15.0	2.5			
PBR 140135097	140	135.0	9.7	2.5			
PBR 140135150	140	135.0	15.0	2.5			
PBR 140133200	140	133.0	20.0	3.5			
PBR 140133350	140	133.0	35.0	3.5			
PBR 150145097	150	145.0	9.7	2.5			
PBR 150145150	150	145.0	15.0	2.5			
PBR 150143200	150	143.0	20.0	3.5			
PBR 150143350	150	143.0	35.0	3.5			

Nominal Dimensions & Machining Tolerances

Claron Part Number	H9		f8		+0.20 -0.00 L ₁	Nom. Sec. S	E
	ØD ₁	ØD ₂	Ød ₁	Ød ₂			
PBR 160155097	160		155		9.7	2.5	
PBR 160155150	160		155		15.0	2.5	
PBR 160153200	160		153		20.0	3.5	
PBR 160153400	160		153		40.0	3.5	
PBR 170165097	170		165		9.7	2.5	
PBR 170165150	170		165		15.0	2.5	
PBR 170162250	170		162		25.0	4.0	
PBR 170162450	170		162		45.0	4.0	
PBR 180175097	180		175		9.7	2.5	
PBR 180175150	180		175		15.0	2.5	
PBR 180172250	180		172		25.0	4.0	
PBR 180172450	180		172		45.0	4.0	
PBR 190185097	190		185		9.7	2.5	
PBR 190185150	190		185		15.0	2.5	
PBR 190182250	190		182		25.0	4.0	
PBR 190182450	190		182		45.0	4.0	
PBR 200195097	200		195		9.7	2.5	
PBR 200195150	200		195		15.0	2.5	
PBR 200192250	200		192		25.0	4.0	
PBR 200192450	200		192		45.0	4.0	
PBR 210205097	210		205		9.7	2.5	
PBR 210205150	210		205		15.0	2.5	
PBR 210202250	210		202		25.0	4.0	
PBR 210202500	210		202		50.0	4.0	
PBR 220215097	220		215		9.7	2.5	
PBR 220215150	220		215		15.0	2.5	
PBR 220212500	220		212		50.0	4.0	
PBR 225217250	225		217		25.0	4.0	
PBR 230225097	230		225		9.7	2.5	
PBR 230225150	230		225		15.0	2.5	
PBR 230225097	230		222		30.0	4.0	
PBR 230222550	230		222		55.0	4.0	
PBR 240235097	240		235		9.7	2.5	
PBR 240235150	240		235		15.0	2.5	
PBR 240232300	240		232		30.0	4.0	
PBR 240232550	240		232		55.0	4.0	
PBR 250245097	250		245		9.7	2.5	
PBR 250245150	250		245		15.0	2.5	
PBR 250242300	250		242		30.0	4.0	
PBR 250242550	250		242		55.0	4.0	
PBR 260255097	260		255		9.7	2.5	
PBR 260255150	260		255		15.0	2.5	
PBR 260252600	260		252		60.0	4.0	
PBR 270265097	270		265		9.7	2.5	
PBR 270265150	270		265		15.0	2.5	

1.0 to 2.0

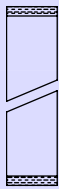

ClaronPolyseal®

Piston & Rod Bearing Rings

PBR

Metric

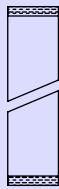

Nominal Dimensions & Machining Tolerances

Claron Part Number	H9		f8		+0.20 -0.00 L ₁	Nom. Sec. S	E
	∅D ₁	∅D ₂	∅d ₁	∅d ₂			
PBR 270262600	270		262		60.0	4.0	1.0 to 2.0
PBR 280275150	280		275		15.0	2.5	
PBR 280275250	280		275		25.0	2.5	
PBR 280272250	280		272		25.0	4.0	
PBR 320315150	320		315		15.0	2.5	
PBR 320315250	320		315		25.0	2.5	
PBR 320312250	320		312		25.0	4.0	
PBR 360355150	360		355		15.0	2.5	
PBR 360352250	360		352		25.0	4.0	
PBR 400395150	400		395		15.0	2.5	
PBR 400395250	400		395		25.0	2.5	
PBR 400392250	400		392		25.0	4.0	
PBR 450445150	450		445		15.0	2.5	
PBR 450445250	450		445		25.0	2.5	
PBR 450442250	450		442		25.0	4.0	
PBR 500495150	500		495		15.0	2.5	
PBR 500495250	500		495		25.0	2.5	
PBR 500492250	500		492		25.0	4.0	